



Routine maintenance alarm



Condenser air filter



Front ON - OFF switch

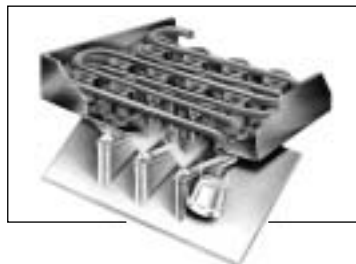

Spray bar quick disconnect



Patented scale-guard system



Hygienic scoop holder



Storage bin antibacterial pouch holder

- AC 46
- AC 56
- AC 86
- AC 106
- AC 126
- AC 176
- AC 206
- AC 226

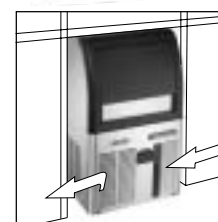
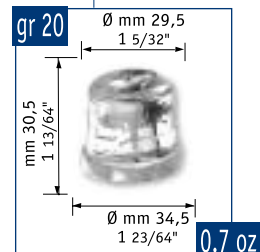

**Automatic
Gourmet-Cube
Ice Machine**

**Machine
Automatique
à Glaçons
Gourmet**

**Automatischer
Gourmetkegel-
eisbereiter**

**Màquina
Automàtica
Fabricadora
de Cubitos
Gourmet**

**Produttore
Automatico
di Ghiaccio
a Cubetti
Gourmet**

Model	Temperature Range	Production Capacity						Dimensions (mm)	Dimensions (inches)	Weight (kg)		
		10° : 10°C			21° : 15°C							
		[kg]	[lbs]	N°*	[kg]	[lbs]	N°*	[WxDxH mm]	[WxDxH inches]			
AC 46 AS	10° - 15°C	24,5	54	1225	22	48	1100	9 20 450	230/50/1	386x600x643	15 3/16"x23 5/8"x25 5/16"	R 134 a
AC 46 WS	10° - 15°C	24,5	54	1225	22,5	49	1125	9 20 450	230/50/1	386x600x643	15 3/16"x23 5/8"x25 5/16"	R 134 a

* Estimate number of medium size gourmet cubes.
Optional: Kit legs - code n. kitlegssocket
Optional: PWD System

www.scotsman-ice.com
www.scotsman-ice.it

2

Years Warranty
Ans de Garantie
Jahre Garantie
Años de Garantía
Anni di Garanzia

Subject to certain limitations and exclusions
Assujettie aux limites et exclusions prescrites
Abhängig von Bestimmten Einschränkungen und Ausnahmen
Sujeta a algunas limitaciones y exclusiones
Soggetta ad alcune limitazioni ed esclusioni



AC 46

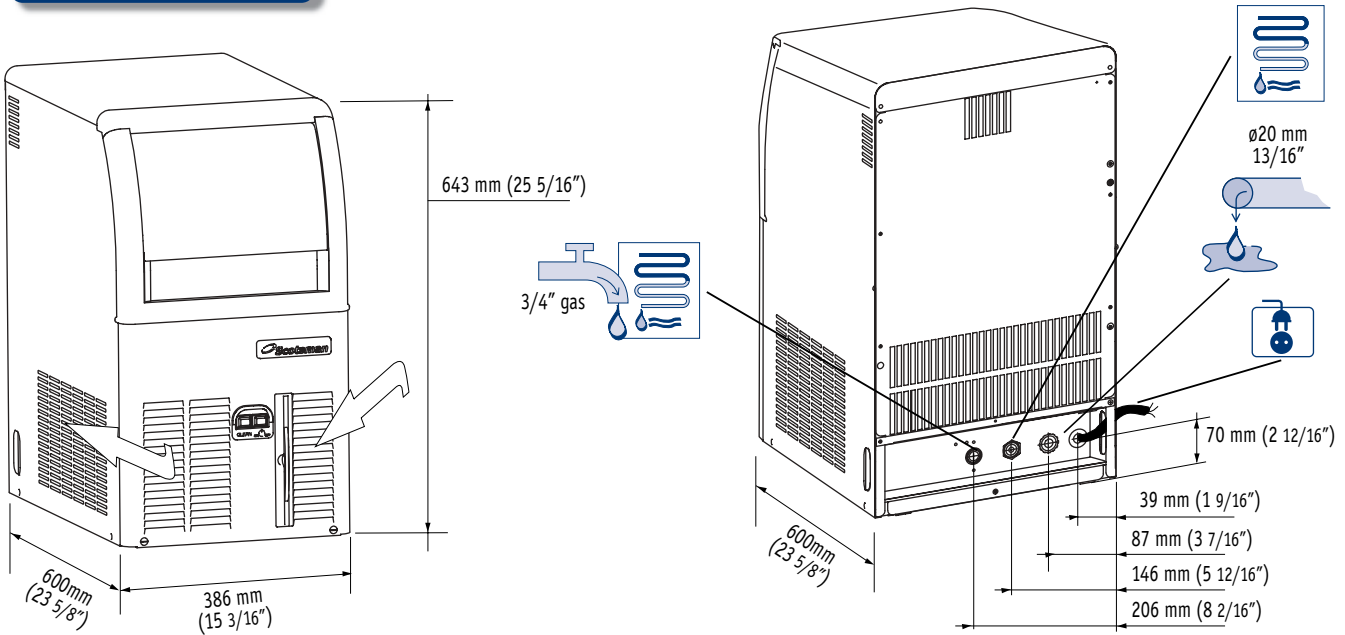

Model	Compressor	Capacity [Btu/h] [W]	Ice Output [kg] [lbs]	Ice Thickness [mm]	Power [W]	FUSE [A]	Energy [kWh]	Water [l/h] [gal/h]	Weight [kg] [lbs]	Dimensions [kg] [lbs]
AC 46 AS		2730 800	35 77	1,5	400	10	8	3.2 0.84	42 93	35 77
AC 46 WS		2730 800	42 93	1,5	400	10	6	27.3 7.2	42 93	35 77

AC 46 AIR COOLED



°C / °F	50° / 10°	60° / 15°	70° / 21°	90° / 32°	
10°	24.5	24	23.5	22.5	kg
50°	54	53	52	49	lbs
21°	22.5	22	21.5	20.5	kg
70°	49	48	47	45	lbs
32°	19.5	19	18.5	17.5	kg
90°	43	42	41	41	lbs
38°	18	17.5	17	16	kg
100	39	38	37	35	lbs

24h



Machine requires voltage indicated on rating name plate. Failures caused by improper voltage are not considered factory defects. Scotsman products are not designed for outdoor installation. Extended periods of operation at temperatures exceeding the above limitations constitutes misuse under the terms of Scotsman Limited Warranty, resulting in a loss.

La machine doit être raccordée conformément au voltage indiqué sur la plaque signalétique. Les éventuels dégâts causés par un non respect de cette consigne ne peuvent être considérés comme des défauts de fabrication. Les machines à glace Scotsman ne sont pas conçues pour être utilisées à l'extérieur. Le fonctionnement prolongé à des températures supérieures ou inférieures aux limites ci-dessus sont considérées comme une mauvaise utilisation dans le cadre de la garantie Scotsman.

AC 46 WATER COOLED



°C / °F	50° / 10°	60° / 15°	70° / 21°	90° / 32°	
10°	24.5	24	23.5	22.5	kg
50°	54	53	52	49	lbs
21°	23	22.5	22	21	kg
70°	50	49	48	45	lbs
32°	22	21.5	21	20	kg
90°	48	47	45	40	lbs
38°	20	19.5	19	18	kg
100	40	43	42	39	lbs

24h



Der Eisbereiter benötigt eine Stromspannung gemäß Gerätee-Typenschild. Störungen oder Ausfälle, durch den Betrieb mit falscher Stromspannung sind keine Fabrikationsfehler und fallen nicht unter Garantie. Scotsman Eisbereiter sind nicht für die Installation im Freien geeignet. Der längere Betrieb bei Temperaturen über den obigen Grenzwerten ist eine falsche Anwendung und bedeutet den Verlust der Garantieleistung.

Los requerimientos eléctricos de la máquina están indicados en la placa de características. Los daños causados por voltajes inadecuados no son considerados defectos de fábrica. La máquina de hielo Scotsman, no están diseñadas para trabajar a la intemperie. Largos periodos de funcionamiento a temperaturas que excedan de las limitaciones indicadas, constituyen maltrato de acuerdo con las observaciones de Scotsman.

La macchina richiede il voltaggio indicato sulla targhetta di identificazione. Danni causati da voltaggi diversi non sono considerati difetti di produzione. I prodotti Scotsman non vanno utilizzati all'aperto. Un prolungato periodo di utilizzo al di fuori delle temperature indicate non è consentito e causa l'automatico decadere della garanzia.



Minimum

10°C (50°F)



Maximum

40°C (104°F)

5°C (41°F)

-10%

1 BAR
14 psi



35°C (95°F)

+10%

5 BAR
70 psi



Scotsman
Ice Systems

The one the world relies on.

Certified ISO 9001:2000

USA, Canada, Latin America

Scotsman Ice Systems USA
775 Corporate Woods Parkway
Vernon Hills, IL 60061
Ph: (+1) 847 215-4550
Fax (+1) 847 913-9844
customer.service@scotsman-ice.com

Europe

Scotsman Europe-Frimont S.p.A.
Via Puccini, 22
20010 Pogliano (Milano) Italy
Ph: (+39) 02-93960208
Fax: (+39) 02-93960201
scotsman.europe@frimont.it

Asia and Pacific

Scotsman Ice Systems-Frimont S.p.A. (R.O.)
627A Aljunied Road #04-04 Biztech Centre
Singapore 389842
Ph: (+65) 6738 5393
Fax: (+65) 6738 1959
scotice@singnet.com.sg

China

Scotsman Ice Systems
258 Tong Ren Road Golden Tower 7A
Shanghai-200040 Peoples Republic of China
Ph: (+86) 21-62476056
Fax: (+86) 21-62476126
scotsmash@online.sh.cn

Middle East & N. Africa

Scotsman Ice Systems Dubai Office
P.o. Box 13205 - Deira
Dubai - U.A.E.
Mobile Ph: (+971) 505505980
Fax (+971) 6-5654063
scotsman@emirates.net.ae

South Africa

Scotsman Ice Systems SA (PTY) Ltd.
10, Rhodes Street - Kensington B
P.o. Box 44 - Riverclub 2149
Ph: (+27) 11-7898400
Fax (+27) 11-7898411
scotsman@telkomsa.net