

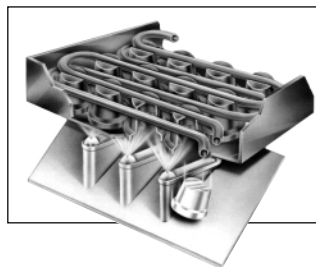

ICE one  
ICE two  
ICE three



**GOURMET ICE CUBE**



**SS AISI 304**

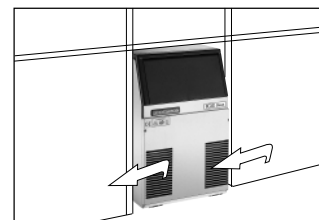

**Automatic  
Gourmet-Cube  
Ice Maker**

**Machine  
Automatique  
à Glaçons  
Gourmet**

**Automatischer  
Gourmetkegel-  
eisbereiter**

**Màquina  
Automàtica  
Fabricadora  
de Cubitos  
Gourmet**

**Produttore  
Automatico  
di Ghiaccio  
a Cubetti  
Gourmet**

ICE THREE AS		24h	38 [kg] 83.6 [lbs] 1900 [N°]	14 [kg] 31 [lbs] 700 [N°]	230/50/1	790x457x522 [HxWxD mm] 31"x18" x 20" [HxWxD inches]	H=790+120 [H mm] 31"+4 3/4" [H inches]	R 134 a
ICE THREE WS		24h	39 [kg] 85.8 [lbs] 1950 [N°]	14 [kg] 31 [lbs] 700 [N°]	230/50/1	790x457x522 [HxWxD mm] 31"x18" x 20" [HxWxD inches]	H=790+120 [H mm] 31"+4 3/4" [H inches]	R 134 a

**2**

Years Warranty  
Ans de Garantie  
Jahre Garantie  
Años de Garantia  
Anni di Garanzia

Subject to certain limitations and exclusions  
Assujettie aux limites et exclusions prescrites  
Abhängig von Bestimmten Einschränkungen und Ausnahmen  
Sujeta a algunas limitaciones y exclusiones  
Soggetta ad alcune limitazioni ed esclusioni



This product qualifies for the following listings:



# ICE three

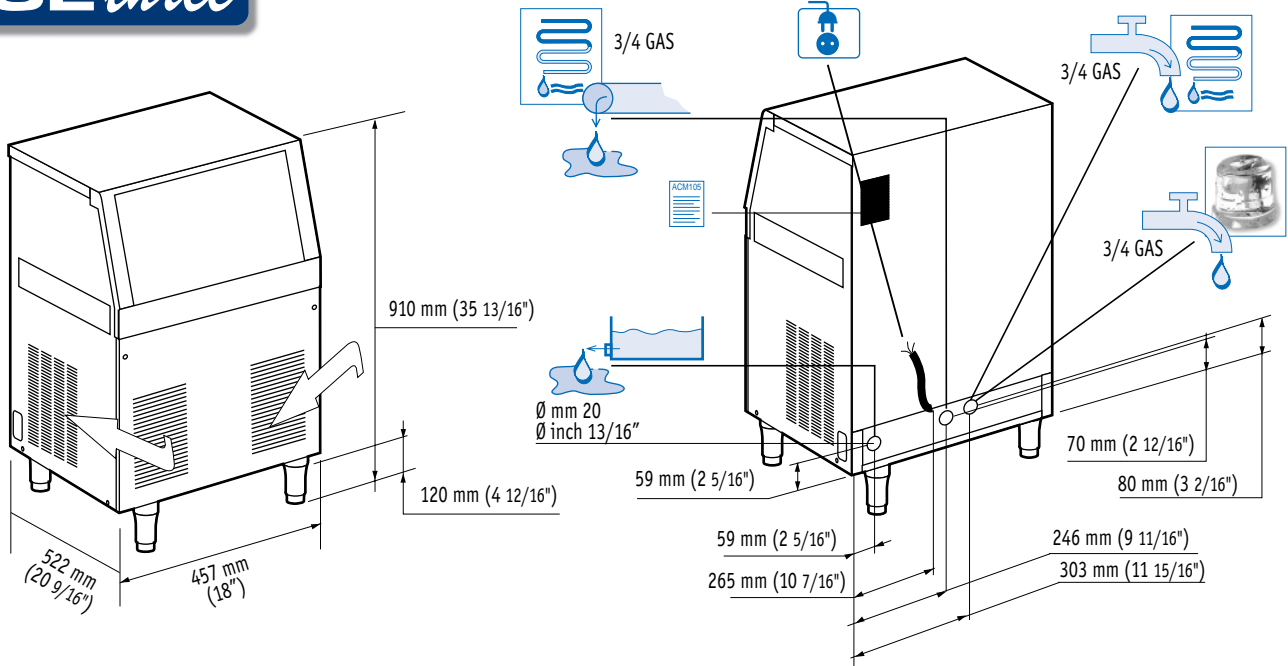

	[Btu/h]	[W]	[Ømm <sup>2</sup> ]	[W]	FUSE	[kWh]	[l/h]	[gal/h]	[kg]	[lbs]	[kg]	[lbs]
ICE THREE AS	4235	1245	3x1	500	10 A	10	6	1,6	48	105	55	121
ICE THREE WS	4235	1245	3x1	500	10 A	10	25	6,6	47	103	54	119

## ICE THREE AIR



°F	50°	60°	70°	90°	
°C	10°	15°	21°	32°	
10°	38	36.5	35	32	kg
50°	84	80	77	70	lbs
21°	37.5	36	34.5	31.5	kg
70°	82	79	76	69	lbs
32°	33.5	32	30.5	27.5	kg
90°	74	70	67	60	lbs
38°	32	30.5	29	26	kg
100	70	67	64	57	lbs



Machine requires voltage indicated on rating name plate. Failures caused by improper voltage are not considered factory defects. Scotsman products are not designed for outdoor installation. Extended periods of operation at temperatures exceeding the above limitations constitutes misuse under the terms of Scotsman Limited Warranty, resulting in a loss.

La machine doit être raccordée conformément au voltage indiqué sur la plaque signalétique. Les éventuels dégâts causés par un non respect de cette consigne ne peuvent être considérés comme des défauts de fabrication. Les machines à glace Scotsman ne sont pas conçues pour être utilisées à l'extérieur. Le fonctionnement prolongé à des températures supérieures ou inférieures aux limites ci-dessus sont considérées comme une mauvaise utilisation dans le cadre de la garantie Scotsman.

## ICE THREE WATER



°F	50°	60°	70°	90°	
°C	10°	15°	21°	32°	
10°	39	37.5	36	33	kg
50°	86	83	79	73	lbs
21°	38.5	37	35.5	32.5	kg
70°	85	81	78	72	lbs
32°	37	35.5	34	31	kg
90°	81	78	75	68	lbs
38°	36	34.5	33	30	kg
100	79	76	73	66	lbs



Der Eisbereiter benötigt eine Stromspannung gemäß Geräte-Typenschild. Störungen oder Ausfälle, durch den Betrieb mit falscher Stromspannung sind keine Fabrikationsfehler und fallen nicht unter Garantie. Scotsman Eisbereiter sind nicht für die Installation im Freien geeignet. Der längere Betrieb bei Temperaturen über den obigen Grenzwerten ist eine falsche Anwendung und bedeutet den Verlust der Garantieleistung.

Minimum	Maximum
10°C (50°F)	40°C (104°F)
5°C (41°F)	35°C (95°F)
-10%	+10%
1 BAR 14 psi	5 BAR 70 psi

Los requerimientos eléctricos de la máquina están indicados en la placa de características. Los daños causados por voltajes inadecuados no son considerados defectos de fábrica. La máquinas de hielo Scotsman, no están diseñadas para trabajar a la intemperie. Largos periodos de funcionamiento a temperaturas que excedan de las limitaciones indicadas, constituyen maltrato de acuerdo con las observaciones de Scotsman.

La macchina richiede il voltaggio indicato sulla targhetta di identificazione. Danni causati da voltaggi diversi non sono considerati difetti di produzione. I prodotti Scotsman non vanno utilizzati all'aperto. Un prolungato periodo di utilizzo al di fuori delle temperature indicate non è consentito e causa l'automatico decadere della garanzia.



**Scotsman**<sup>®</sup>  
Ice Systems

The one the world relies on.

USA, Canada, Central and South America  
Scotsman Ice Systems USA  
775 Corporate Woods Parkway  
Vernon Hills, IL 60061  
Ph: (847) 215-4550  
Fax (847) 913-9844  
E-Mail: customer.service@scotsman-ice.com

Europe, Middle East and Africa  
Scotsman Europe - Frimont S.p.A.  
Via Puccini, 22  
20010 Bettolino di Pogliano (Milano) Italy  
Ph: (+39) 02-93960208  
Fax: (+39) 02-93960201  
E-Mail: scotsman.europe@frimont.it

Asia and Pacific  
Scotsman Ice Systems-Frimont S.p.A. (R.O.)  
627A Aljunied Road-#04-04 Biztech Centre  
Singapore 389842  
Ph: (+65) 6738 5393-Fax: (+65) 6738 1959  
E-mail (general): scotsice@singnet.com.sg  
E-mail (service): scotserv@singnet.com.sg

China  
Scotsman Ice Systems  
258 Tong Ren Road Golden Tower 7A  
Shanghai-200040 Peoples's Republic of China  
Ph: (+86) 21-62476056  
Fax: (+86) 21-62476126  
E-mail: scotsmansh@online.sh.cn



South Africa  
Scotsman Ice Systems S.A.Pty: Ltd.  
69, Audley Road - 2021 Bryanston  
P.O. Box 44 - 2149 Riverclub-S. Africa  
Ph: +27-11-4636244/5  
Fax +27-11-4631411  
E-Mail: scotsman@telkomsa.net